

***Ansoft - CSU CREATE - NASA  
Aerospace Power and Electronics Simulation  
Workshop***

***Concurrent Engineering Design Practice for Aerospace  
Power***

***Raymond F Beach***

***NASA Glenn Research Center***

***October 8, 2003***

# ***Concurrent Engineering Defined As***

- ***Old Program Manager's Description***
  - ***Jim Sullivan, Westinghouse Lima***
- ***NASA Formal Definition***
  - ***NASA Systems Engineering Handbook SP6105***
    - ***"Concurrent engineering is the simultaneous consideration of product and process downstream requirements by multidisciplinary teams."***
- ***NASA / Aerospace Practice***
  - ***ISS Power System Development Experience***
  - ***Process Best Describe As Puddles Of Activities That Are Brought Together By Management At Gated Reviews***
    - ***Many Parallel Activities By Contractors And Centers Without Real Time Interaction***
  - ***Process Not Changed Since WWII***

## ***Aerospace External Forces And Trends***

- ***Erosion In NASA Mission Center Design Experience***
  - ***Cost Driven***
  - ***Early Space Program Required In-house Parallel Development Activities To Minimize Risk***
- ***Aero Industry Now Outsourcing Subsystem Design Activities***
  - ***Following Same Trend As NASA***
- ***Automobile Industry Began Outsourcing Trend Before Aero***
  - ***Space Industry Following Same Trend***
- ***Power Electronics Industry***
  - ***Industry Founded To Support Aerospace Needs***
  - ***All US Power Electronics Consumed By Aerospace In 1960s***
  - ***Aerospace Only A Small Fraction In 1990s***
- ***Future Aerospace Power Systems And Components***
  - ***More Complex, Higher Power, Higher Reliability, Higher Level of Integration***

## ***How Do We Adapt?***

- ***Reverse Management Direction ?***
  - ***Multiple Industry in U.S. All Following Course***
  - ***Federal Government Agencies Following Course***
  - ***Not Likely Because of Cost Drivers***
  - ***Probably is Right Direction***
- ***Adapt for the Future***
  - ***What Does Adaptation Involve***
    - ***Control Engineering as Model***
    - ***Concurrent Engineering***
    - ***Real Time Engineering***
    - ***Integrated Engineering Environment***

## ***Relevancy to Workshop***

- ***Solution Lies In Better Utilization Of Increased Computational Power***
  - ***Interoperability Of S/W***
  - ***Linked Through H/W Networks***
  - ***Example: Electric Circuit Simulation History***
  - ***Example: TMIS***
- ***Ansoft History***
- ***Integrated Design Environment Objectives***
  - ***Utilization Of Off-the-shelf S/W***
  - ***Integration Of Systems, Design, Manufacturing Engineering***
  - ***Interoperability Of Engineering Tools***
  - ***Process Documentation And Knowledge Capture***
  - ***Analytic Model Fidelity And Availability Linked To H/W***
  - ***Management Interface And Oversight***

# *Integrated Product Example Spacecraft Flywheel Module*

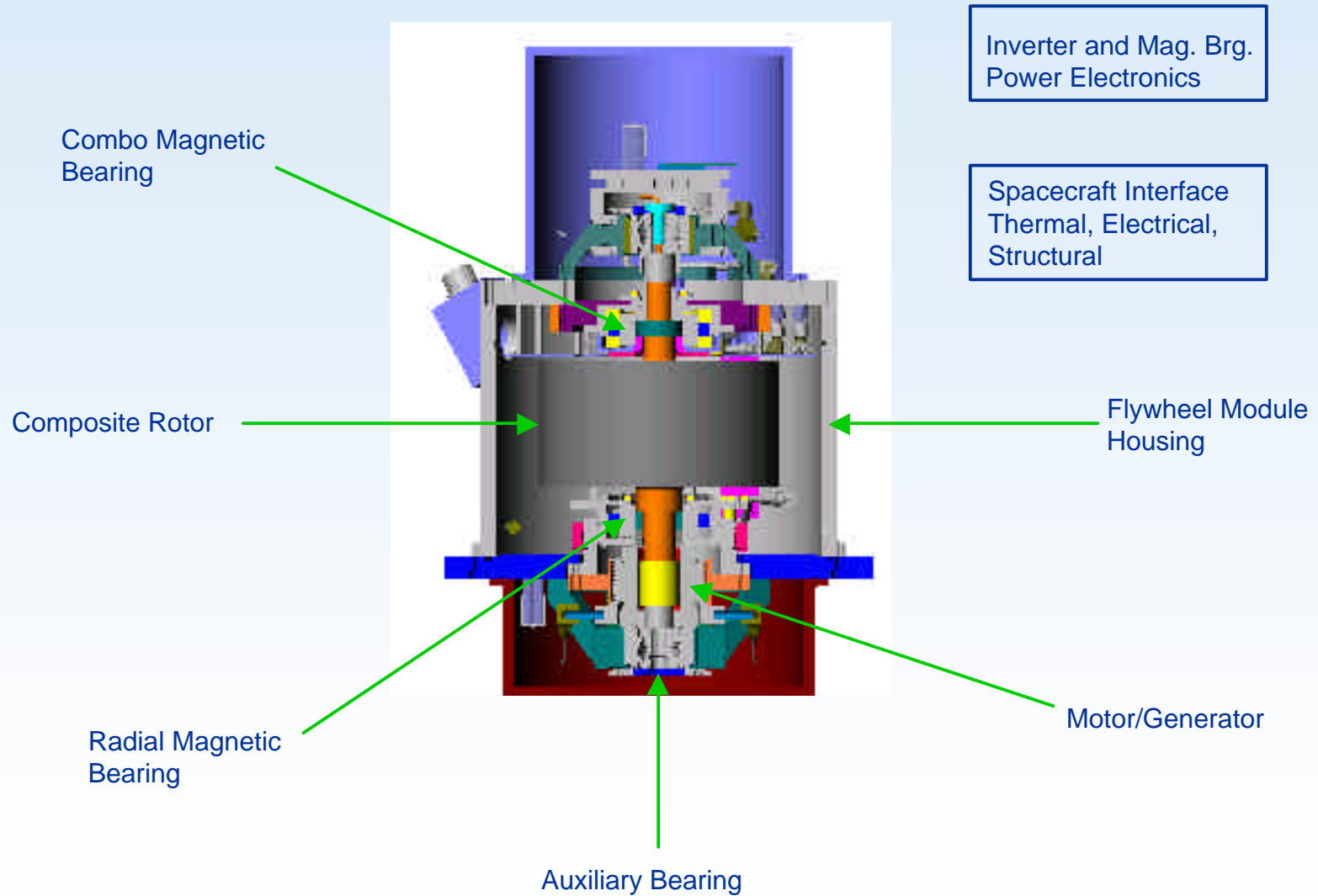

# Enterprise/Mission

# Integrated Design Environment

## Program/Project

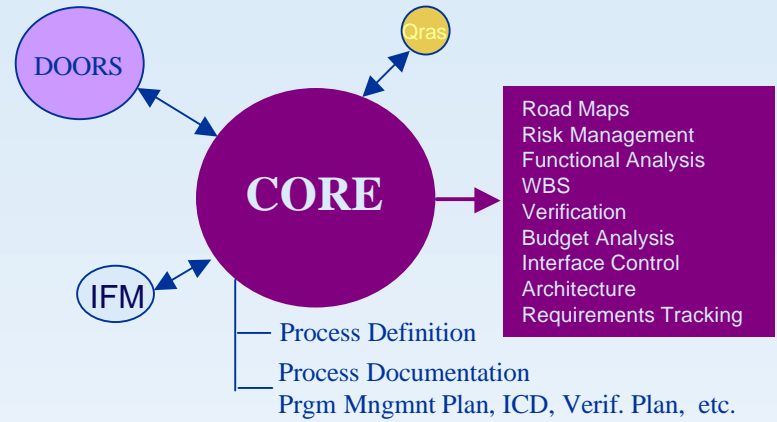

## Analysis/Design

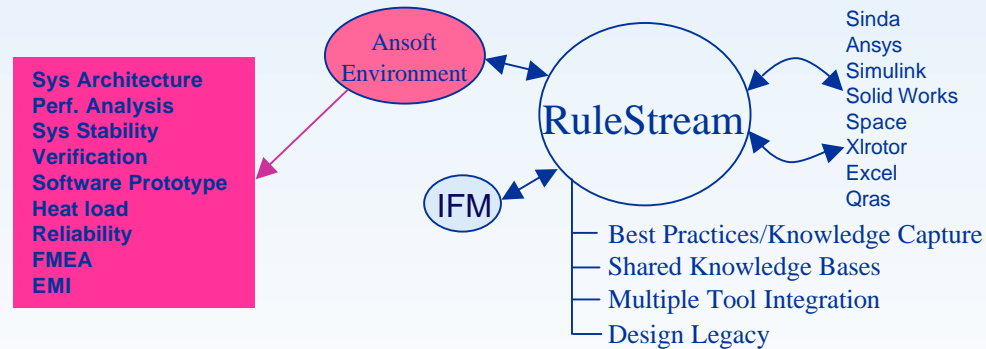

## Design/Manufacture

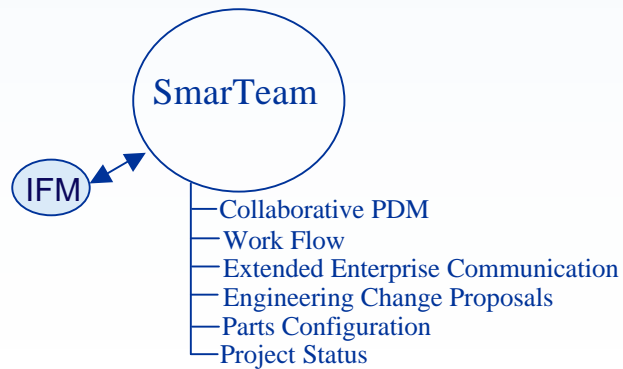

# Core Product Overview

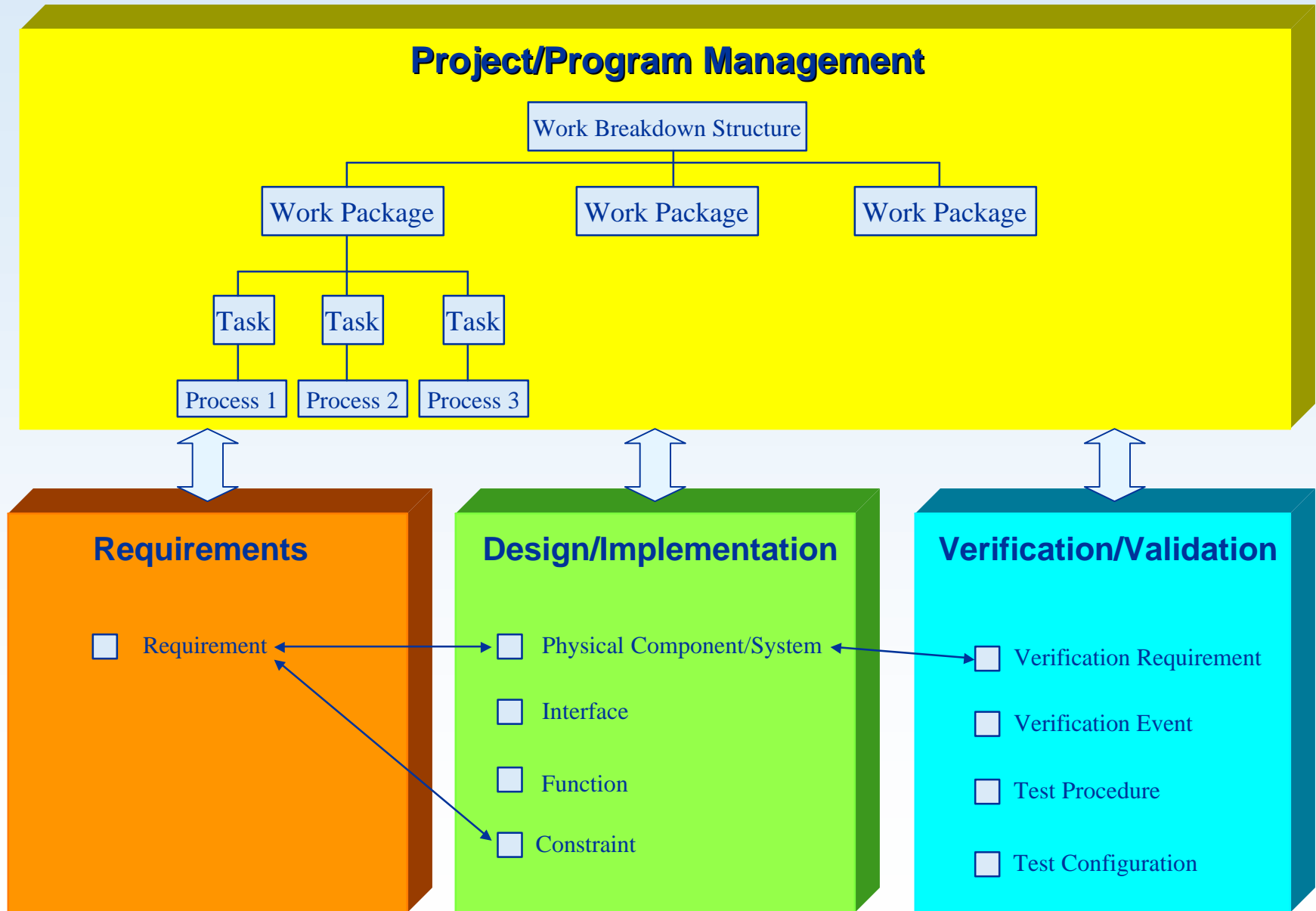

# Ansoft Environment

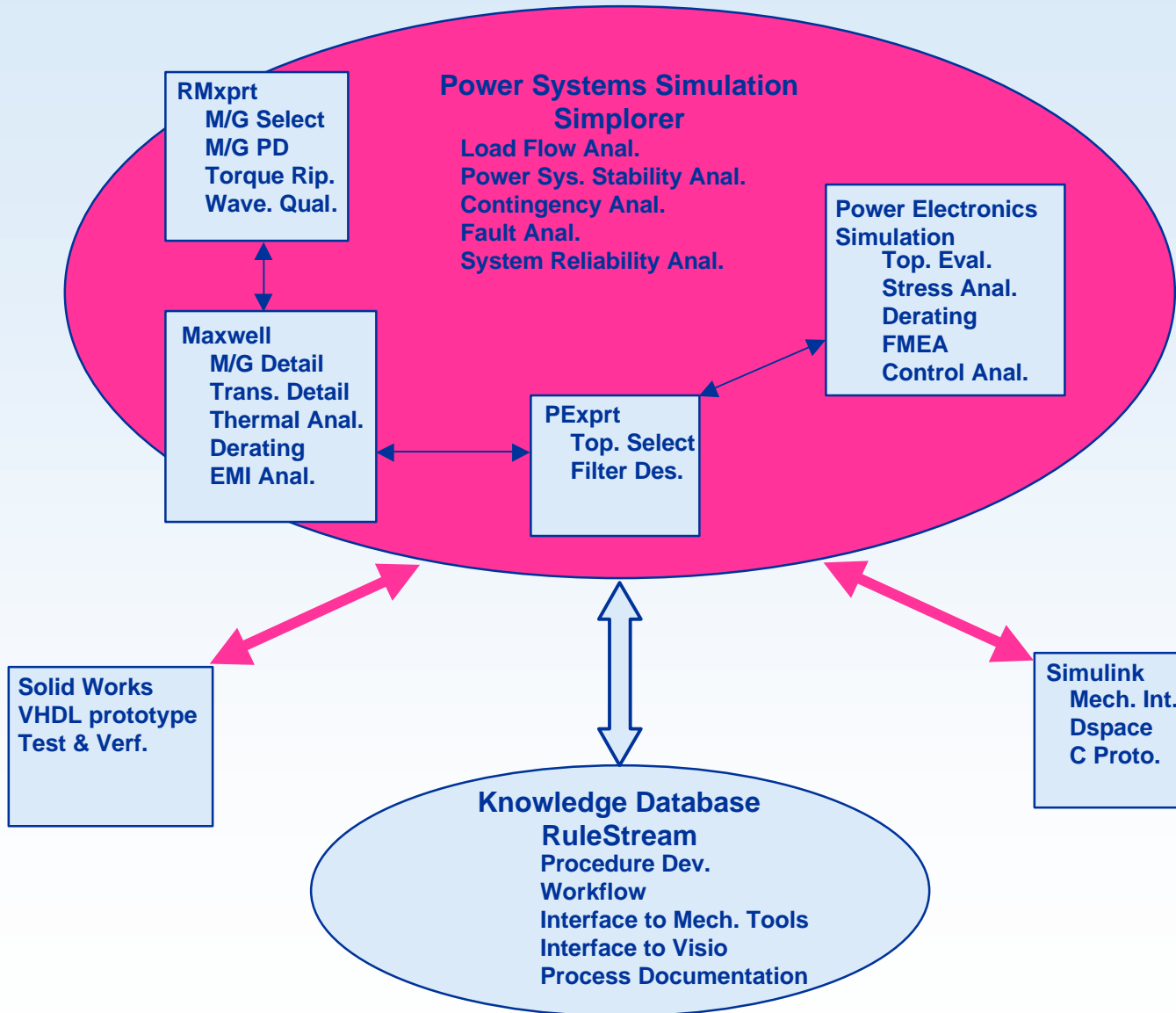

# Power System Design Cycle and Tools Utilization

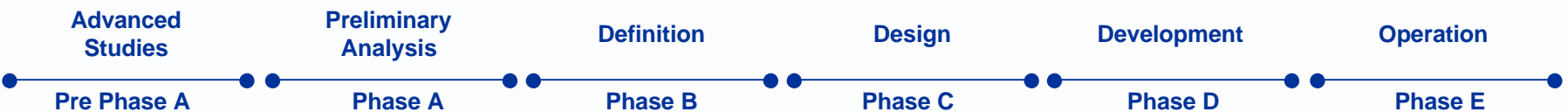
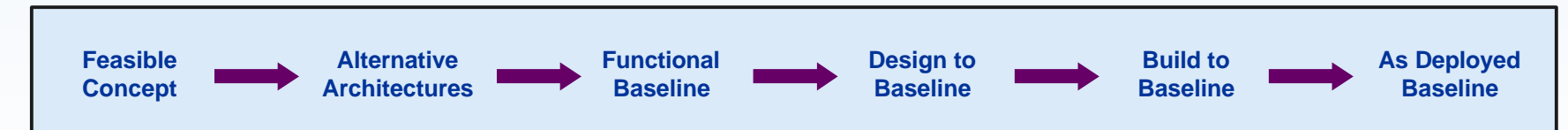
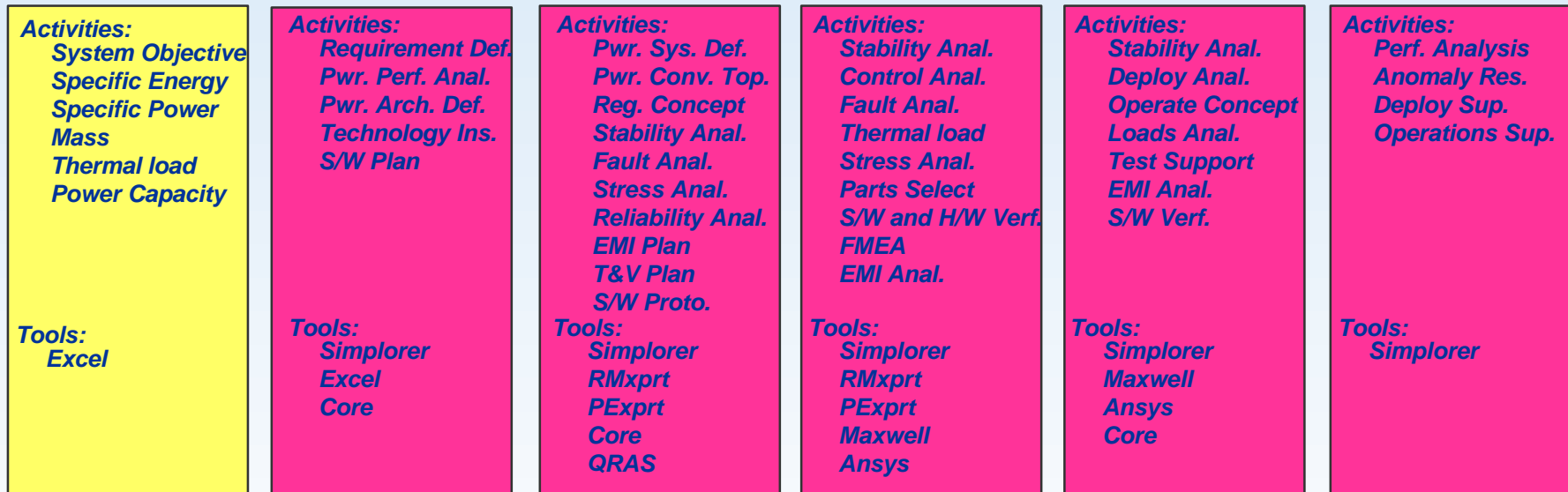

# Tool Utilization For Flywheel Module Design

Simulink

Housing  
Auxiliary Brg.  
Spacecraft Structure  
Rotordynamics

PExprt

Inverter and Mag. Brg.  
Power Electronics

RMxpprt

Motor/Generator

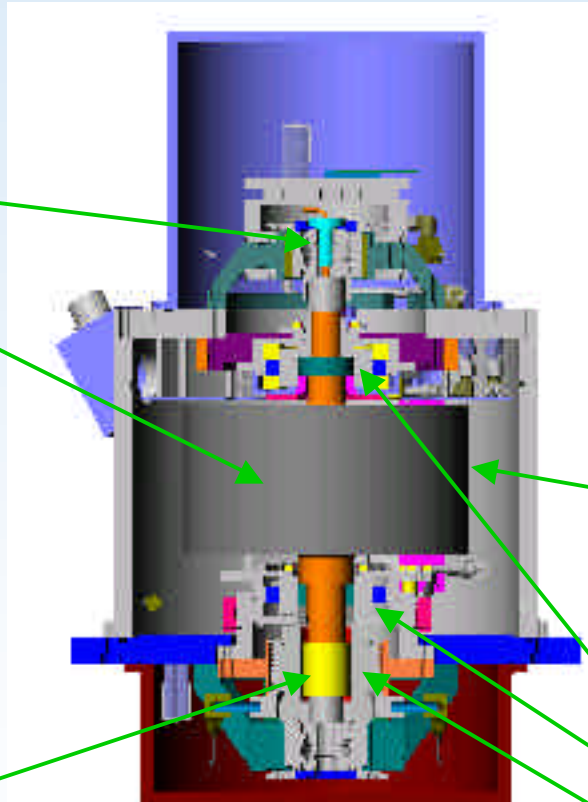

Simplorer

Spacecraft Electric  
System  
Inverter and Mag. Brg.  
Power Electronics

Ansys

Rotor Stress Anal.  
Mod Level Thermal Anal.

Maxwell

Radial and Combo Mag. Brg.  
Motor/Generator

## ***Planned Ansoft Environment Activities***

- ***Currently Working With Ansoft To Enhance Electric Power Analysis And Simulation Capability***
  - ***FPGA VHDL Prototyping and Verification Capability With Simplorer***
  - ***Library Of Power Components For Aerospace***
  - ***2D and 3D CAD Linkage***
  - ***Development of Interface To RuleStream Knowledge Database***

# RuleStream Product Overview

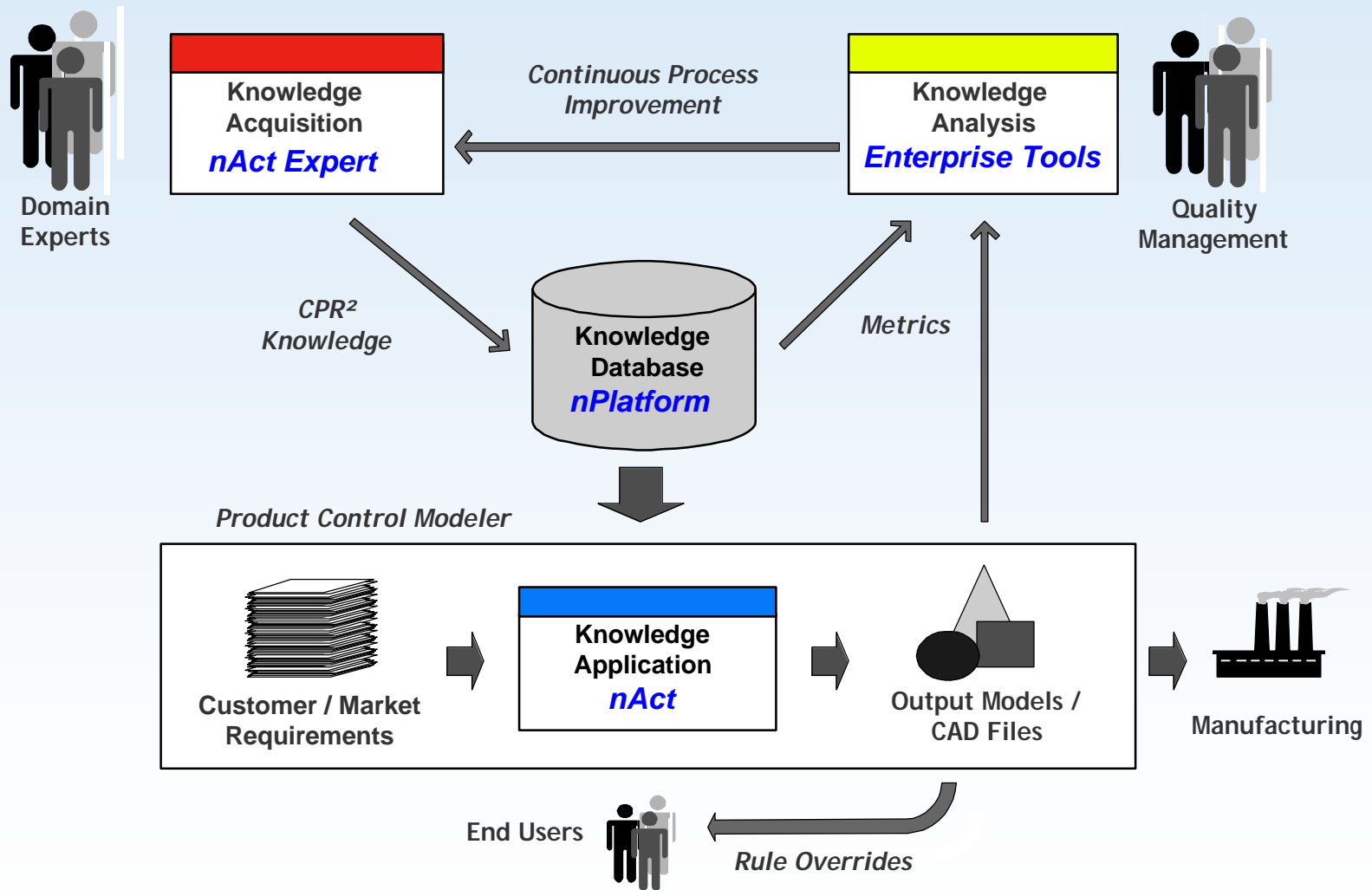

# SmarTeam Product Overview

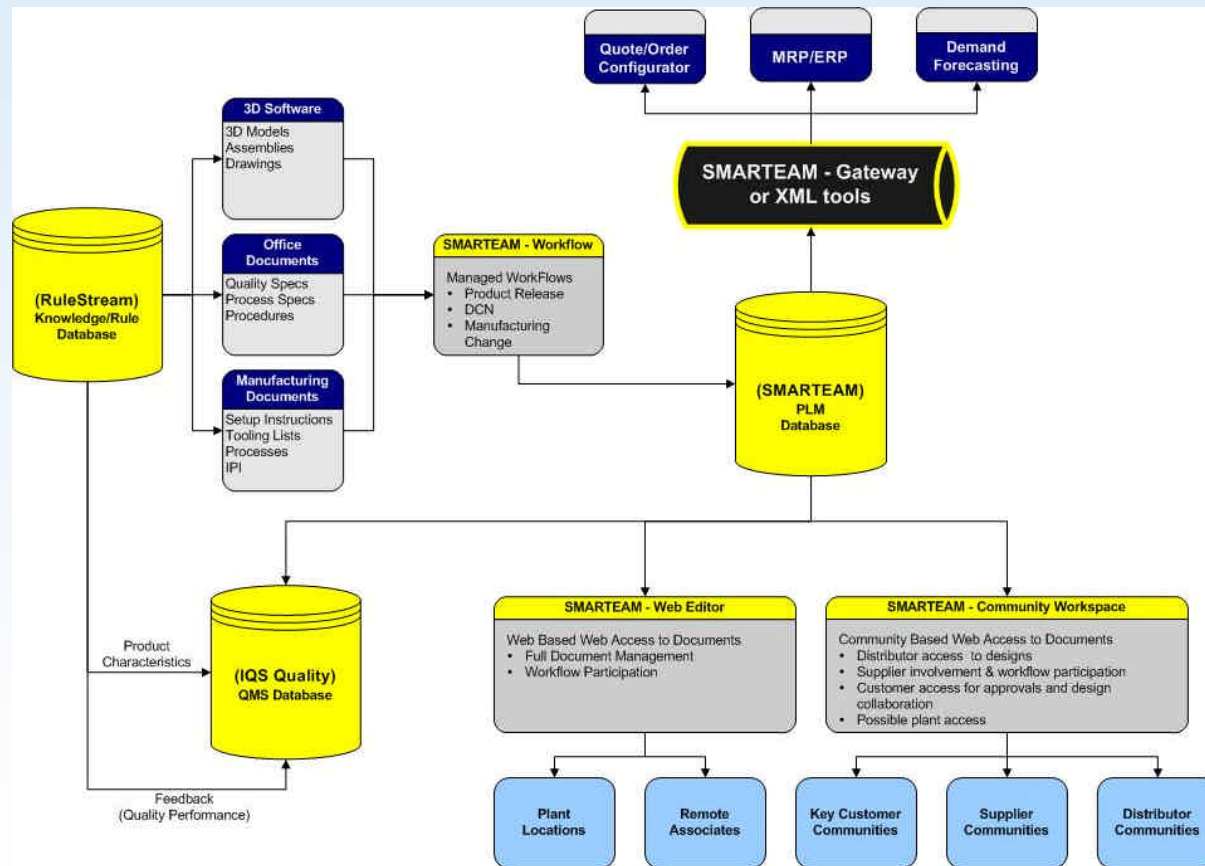

# Thoughts on Future Design Environment

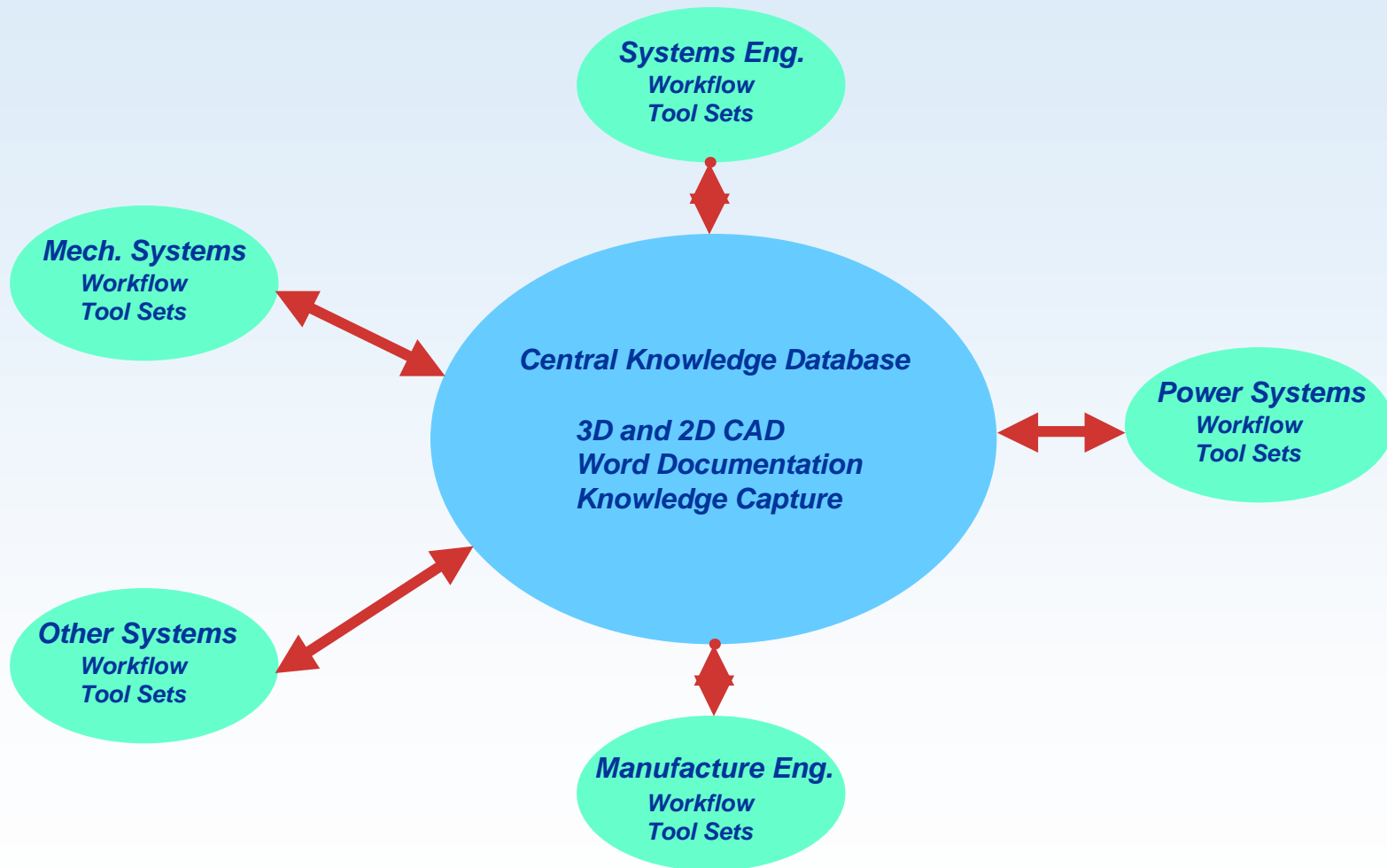

## ***Future Directions***

- ***Collaborative Effort With CSU CREATE***
  - ***Develop IDE To Support Joint NASA, CSU Activities***
  - ***Expand IDE Capability To Incorporate Teaching and Learning Objectives***
  - ***Develop Insights For Future Design Environment Directions***
- ***Working With Primes (Boeing, Northrup Grumman, and Lockheed Martin) To Develop Common Development Interests And Tasks***